

THERMOSALD

**THERMOREGULATOR
FOR
IMPULSE WELDING
OF
POLYETHYLENE OR PLASTIC FILM
BY SEALING BAND OR WIRE RESISTANCE
(MOD. MICROPROCESSOR + SCR)**

DIRECTION FOR USE AND MAINTENANCE

3E S.r.l.

**Legal site : Via Turati n. 55
40134 BOLOGNA**

**Amm. / Comm. / Prod. site : Via del Maccabreccia 37/a
40012 LIPPO DI CALDERARA (BOLOGNA)**

Tel. ++39-051-6466225 Fax ++39-051-6426252

Internet e-Mail : help3e@iol.it Internet Address : <http://www4.iol.it/3e>

0 WARNING

0.1 NOTE ON SAFETY

HAZARD

Do not use device in explosive environment or with explosive material .

Do not use device with flammable materials without the necessary precautions.

Do not insert the power circuit of thermoregulator when the protections are open .

Do not insert the thermoregulator supplies if the cover is open in case of extraordinary operation on electronic device.

The thermoregulator was projected for a sharp control of rod or wire resistance temperature installed on horizontal or vertical packaging machine, other application must be granted with our technical office , we do not consider us responsible for damage at people, animals, or things caused by improper use.

The installation and start-up must be effectuated following stictly the istruction of the present handbook in respect of security law related at yours machine.

We do not consider us responsible for damage at people, animals, or things caused by improper use.

The thermoregulator is supply of controls related at correct working hardware and software, in the case of damage a contact is open for disconnect the power circuit.

Verify that during normal working the heat sink of the thermoregulator do not reach the 60°C , in this case provide to increase the ventilation near the thermoregulator.

0.2 ELECTROMAGNETICS DIRECTIVE CONFORMITY - CE DECLARATION

Complied directives :

- Low voltage directives : 73/23 CEE - 93/68 CEE (in force from 01/01/97)
 - Electromagnetics compatibility directives : 89/336 CEE - 92/31 CEE - 93/68 CEE (in force from 01/01/96)
 - Machine directives : 89/392 CEE - 91/368 CEE - 93/68 CEE (in force from 01/01/95)
- NOTE - This directive is not direct applicable to electronic product, ours thermoregulators was conceived to allows the compliance at this directive, if correctly installed, following the instruction of this handbook.

Electromagnetics conformity test :

Test condition :

- Mains filter Siemens Mod. B84112-B-B60 (115 / 250 V - 6A - 50/60 Hz)
- Termoregulator - standard display 3ESD0035E connecting cable
- Power input main cables mt. 3 length
- Resistance output cables mt. 10 length

Immunity test :

- We have follow the standard at the directives EN50082-2: generic immunity standard Part 2 : industrial environment .
- IEC 1000-4-2 (IEC 801-2/1991); ELECTROSTATIC DISCHARGES (ESD)
- IEC 1000-4-3 (CEI 801-3); INCOMING ELECTROMAGNETIC FIELD RADIATION
- IEC 1000-4-4 (CEI 801-4); BURST TRANSIENTS
- ENV50141: CONDUCTED DISTURBANCE INDUCED BY RADIO FREQUENCY FIELDS

Emission test :

- We have follow the standard at the directives EN50081 -2: generic emission standard in industrial environment.
- EN55011 (CEI 110-6); LIMITS AND METHODS OF MEASUREMENT OF RADIO DISTURBANCE CHARACTERISTICS OF MEDICALS , INDUSTRIAL, SCIENTIFIC DEVICE (ISM).

Conformity declaration :

- The termoregulator has passed the above-mentioned conformity standard, the termoregulator is a class B device.
- The device is according to EMC directives 89/336 CEE and follows.
- The thermoregulator is according to low voltage directives 73/23 CEE and follows.

0.3 DEFINITION

QUALIFIED PERSONNEL

In the present manual, the expression "qualified personnel" means personnel familiar with the construction, installation, commissioning and maintenance of this type of equipment. The said personnel must also possess the following qualifications:

1. To have attended relevant training courses or to be authorised to connect and disconnect to/from the mains, to earth, and mark circuits and pieces of equipment according to the current safety regulations.
2. To be suitably trained, according to the current safety regulations, for the use and maintenance of the protection and safety equipment.
3. To be completely familiar with all sources of possible dangers and with all provisions pertaining to maintenance.
4. To have attended first aid courses.

DANGER

The word "Danger" in the present manual or marked on the equipment signals the possibility of heavy damage to persons or things in case the appropriate behaviour is not followed.

ATTENTION

The word "Attention" marked on the equipment signals the possibilities of minor injuries, burnings or damage to persons or things in case the appropriate behaviour is not followed.

NOTE

The word "Note" in the present manual indicates product information of particular importance for the operation of

THE PRESENT MANUAL (EDITION 97/11) MAKES VOID AND REPLACES ALL ITS PREVIOUS EDITIONS.

DATA AND TECHNICAL SPECIFICATION CONTAINED HEREIN ARE VALID AT THE TIME OF PRINTING OF THE PRESENT VOLUME.

3E S.r.l. RESERVES THE RIGHT TO MAKE ANY CHANGES TO THE DESCRIBED EQUIPMENT, EVEN WITHOUT PRIOR NOTIFICATION.

THE PRESENT MANUAL CONTAINS INFORMATION CONCERNING THE USE OF THE EQUIPMENT, CONFORMING WITH THE RELEVANT SAFETY AND ELECTRICAL STANDARDS. PLEASE READ THIS INFORMATION CAREFULLY.

INDEX

0	WARNING
0.1	NOTE ON SAFETY
0.2	ELECTROMAGNETICS DIRECTIVE CONFORMITY - CE DECLARATION
0.3	DEFINITION
1	DESCRIPTION
1.1	GENERAL CHARACTERISTICS
1.2	APPLICATION
1.3	OPERATING PRINCIPLE
1.4	SAFETY CONTROLS AND DIAGNOSTICS
2	TECNICAL DATA
3	DIAGRAM
3.1	BLOCK DIAGRAM
3.2	CONNECTION DIAGRAM
3.3	WIRING DIAGRAM CARD - PANEL CONNECTION CABLE
3.4	WIRING DIAGRAM
4	DIMENSIONING
4.1	TRASFORMER DIMENSIONING
4.2	PROTECTION DIMENSIONING
5	PUTTING INTO SERVICE AND CALIBRATION
5.0	FAST CALIBRATING
5.1	MACHINE DATA SETTING (FOR MANUFACTURER)
5.2	CALIBRATION RULES
5.3	SETTING THE PRE-HEATING AND WELDING TEMPERATURE
5.4	TEMPERATURE \ CURRENT DISPLAY
5.5	INITIAL PREHEATING TEMPERATURE
5.6	LOADING THE MACHINE STANDARD DATA (DO NOT USE)
6	WARNING AND ALARM LIST (CAUSE - REMEDY)
7	DATA FOR ORDER
8	DIMENSIONS
App. A	WELDING CYCLE
App. B	DIP SWITCH SW+ AND SW- TABLE
App. C	DIP SWITCH SW1 AND IREAD TABLE
App. D	PUTTING INTO SERVICE CARD

1 DESCRIPTION

1.1 GENERAL CHARACTERISTICS

The termoregulator manufactured by 3E S.r.l. using an Intel processor technology and an SCR power unit. Such termoregulator controls the welding temperature in a closed loop, in order to compensate for possible thermal drifts of welding elements, such as wire resistance .

A pre-heating system brings the welding rod to the required temperature in a few hundred milliseconds, before starting production, to optimize the first welding.

The elements' temperature during production is controlled by a welding system.

The termoregulator was designed to optimize the welding function of the machine on which it is fitted.

Particularly, the internal parameters can be modified simply by following calibration procedures (See Cap.5)

1.2 APPLICATION

The card is particularly suitable for welding polyethylene or other plastic materials for which precise and rapid welding are required.

1.3 OPERATING PRINCIPLE

The operation of the Thermosald card is based on the principle of phase choking to regulate temperature on the welding elements.

A pre-heating temperature can be set (in °C or °F) directly on the equipment panel, while a welding temperature can be set on the resistance.

The equipment receives a welding input from the machine and reaches the welding pre-set temperature for a time which has been set in the machine Plc (or in a precision timer).

A cooling time can be set in the Plc (or in a precision timer); this time value does not depend on the welding card, but on the elements that are present in the close vicinity of the welding resistance and/or wire, for example on the rods' length, on the thermal insulation elements, on air blows, and so on.

1.4 SAFETY CONTROLS AND DIAGNOSTICS

The card signals that tension is present in the mains by switching on the display panel.

The card signals all the alarms described in the section on protections and alarm reset by displaying them on the panel.

A comprehensive alarm signal on the output (contact opening between pins 4 and 5 of CN3) signals to the machine the presence of one of the red led alarms.

2 TECHNICAL DATA

CONTROL SUPPLY (CN2)	230Vac +/- 10% (0,1 A absorption)
POWER SUPPLY	10 - 100V (max 60 A absorption at 100 V)
DIGITAL COMMANDS	24 VDC (12 ma absorption max)
WELDING CONTACT ALARM	250 V 8A cos Φ = 1 250V 5A cos Φ = 0,4
POWER TRASFORMER POWER	Depending on application (Es. 1000 Va)
DISPLAY PANEL SUPPLY	See wiring diagram
POWER SUPPLY FREQUENCY	50 - 60 Hz (can be set by parameter)
ROOM TEMPERATURE	0° C +50° C
PRECISION	\cong +/- 1 °C
PRE-HEATING TEMPERATURE	Can be set from display panel 0 - 250 °C
WELDING TEMPERATURE	Can be set from display panel 0 - 250 °C
WELDING TIME	Defined by PLC (or precision timer)
MAXIMUM WELDING TIME	4 Sec (can be set by parameter)
COOLING TIME	Defined by PLC (or precision timer)
CARD PROTECTION DEGREE	IP00
DISPLAY PANEL PROTECTION DEGREE	IP65

3 DIAGRAM

3.1 BLOCK DIAGRAM

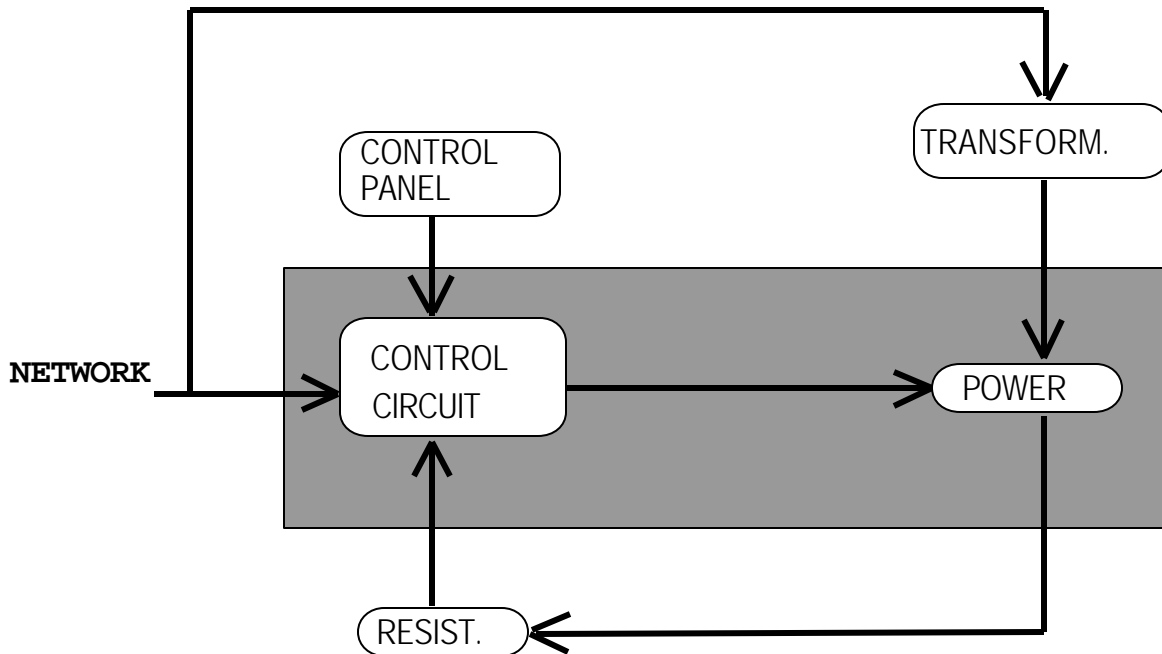

3.2 CONNECTION DIAGRAM

CN1	POWER (Power circuit supply is in fase with control circuit supply)	
PIN1	ALTERNATE SUPPLY	(4 - 6 mmq)
PIN2	ALTERNATE SUPPLY	(4 - 6 mmq)
PIN3	RESISTANCE +	(4 - 6 mmq)
PIN4	RESISTANCE -	(4 - 6 mmq)
PIN5	EARTH	(4 - 6 mmq)
CN2	CONTROL CIRCUIT SUPPLY (Control circuit supply is in fase with power circuit supply)	
PIN 1	230 Vac (0,1A max. absorption)	(1mmq)
PIN 2	230 Vac (0,1A max. absorption)	(1mmq)
CN3	COMMMANDS	
PIN1	COMMON 0 V PLC	(0,5mmq)
PIN2	PRE-HEATING COMMAND INPUT PLC 24V (12 mA max. absorption)	(0,5mmq)
PIN3	WELDING COMMAND INPUT PLC 24 V (12 mA max absorption)	(0,5mmq)
PIN4	WELDING ALARM (CONTACT N.C.) $\cos\Phi = 1$ 250V 8A	(0,5mmq)
PIN5	WELDING ALARM (CONTACT N.C.) $\cos\Phi = 0,4$ 250V 5A	(0,5mmq)
PIN6	RESISTANCE REFERENCE +	(0,5mmq)
PIN7	RESISTANCE REFERENCE -	(0,5mmq)
PIN8	EARTH	(1mmq)
CN4	DISPLAY PANEL	
PIN1	SUPPLY +5V	Screened (0,25mmq)
PIN2	SUPPLY 0 V	Screened (0,25mmq)
PIN3	DATA	Screened (0,25mmq)
PIN4	CLOCK	Screened (0,25mmq)
PIN5	KEY	Screened (0,25mmq)
PIN6	KEY	Screened (0,25mmq)
PIN7	KEY	Screened (0,25mmq)
PIN8	KEY	Screened (0,25mmq)

3.3 WIRING DIAGRAM CARD - PANEL CONNECTION CABLE

CARD SIDE		PANEL SIDE
9 PIN MALE CONNECTOR CANNON		9 PIN FEMALE CONNECTOR CANNON
1 +5V	GREEN	1 +5V
2 0V	RED	2 0V
3 DATA	WHITE	3 DATA
4 CLOCK	YELLOW	4 CLOCK
5 KEY	ORANGE	5 KEY
6 KEY	BROWN	6 KEY
7 KEY	BLACK	7 KEY
8 KEY	BLUE	8 KEY

NOTE

Since this is a digital signal cable, we recommend, in order to comply with the regulation pertaining to electromagnetic equipment, to use a screened, 8 pin by 0.22-0.25 cable and to avoid, if possible, to lay the cable near engines, power transformers, or unscreened power conductors.

The EMC test was execute with the cable lenght of 5 mt., for major length please contact our tecnical office.

3.4 CONNECTION DIAGRAM

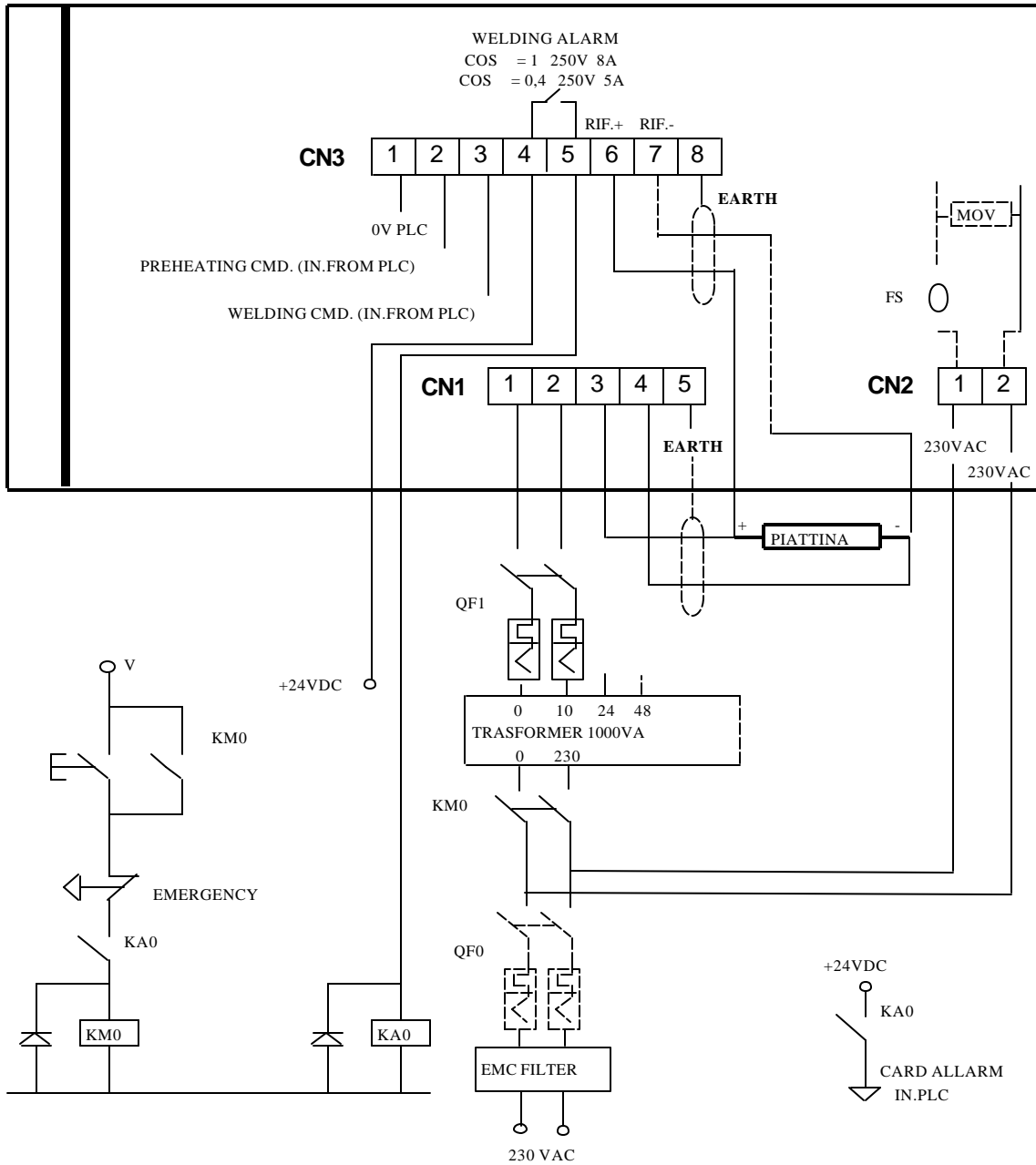

- NOTE

Power circuit supply (CN1/1 e CN1/2) **MUST BE** in fase with control circuit supply (CN2/1 e CN2/2).

The **EARTH** pin must be connected at the machine earth using a yellow-green cable, you can connect also the cable screen.

4 DIMENSIONING

4.1 TRASFORMER DIMENSIONING

READ RESISTANCE VALUE (R) AT RESISTANCE ENDS
CALCULATE SECONDARY TRANSFORMER TENSION
NOMINAL V TRASFORMER $\geq R \times I$ NOMINAL
(FOR CARD 10030 SCR uP : I NOMINALE = 30 A)
(FOR CARD 10060 SCR uP : I NOMINALE = 60 A)

NOTE

In the case that you dont have the right instruments to test the resistance value (R) at the resistance end and you use the welding resistance supply from 3E , you can see the following table :

Resistance width CHANFERED RESISTANCE	Resistance thickness CHANFERED RESISTANCE	Specific Resistance R0 W / mt
3	0.1	2.81
3	0.15	1.95
3	0.2	1.50
3	0.25	1.27
4	0.1	2.37
4	0.15	1.40
4	0.2	1.12
4	0.25	0.96
5	0.2	0.80
6	0.1	1.60
6	0.2	0.72
8	0.1	1.20
8	0.2	0.51

Resistance calculating (R)

- | | | |
|-----|-----------------------|--|
| 1 - | Single resistance | $R = R_0 \times \text{resistance length [mt.]}$ |
| 2 - | 2 series resistance | $R = R_0 \times \text{resistance length [mt.]} \times 2$ |
| 3 - | 2 parallel resistance | $R = R_0 \times \text{resistance length [mt.]} / 2$ |

NB : in the case of copper or silver resistance for " resistance length " mean the part of resistance without copper or silver .

4.2 PROTECTION DIMENSIONING

SEE CAP. 3.4 - CONNECTION DIAGRAM

CN2 - CONTROL CIRCUIT SUPPLY **230 V** : IT IS NOT NECESSARY A PROTECTION BECAUSE IS INTERNALLY (FUSE 315mA AND MOV)

QF0 - TWO-POLE THERMAL-MAGNETIC SWITCH D CURVE OR DELAYED FUSIBLE
(6A WITH TRASFORMER 1000 VA / 8A WITH TRASFORMER 1400 VA)

QF1 - TWO-POLE THERMAL-MAGNETIC SWITCH C CURVE OR DELAYED FUSIBLE
(40A FOR CARD 10030 SCR uP : I NOMINAL = 30A)
(63A FOR CARD 10060 SCR uP : I NOMINAL = 60A)

The suggested value are indicative and must be analized in base at electric plan.

5 PUTTING INTO SERVICE AND CALIBRATION

5.0 FAST CALIBRATING

NOTA

This calibrating can be used only when the dip switch position, machine data and hot calibrating current are know

1 - Make cold balance (the cold balace is make to fit the termoregulator at the resistance) .

Turning the **BALANCING** trimmer , the both led **GREEN** and **RED** must be light simultaneously.
(clockwise rotation lights the **GREEN** led up, counter-clockwise rotation lights the **RED** led up).

The leds update is make one time for seconds, and so when you make the balancing make a rotation and wait for a moment for the update.

2 - Make the hot calibrating

Press the **RESET / MODE** and **UP** button for 3 seconds.
During this fase the display flashing show 3.A.A.A. , left flashing the display until on the display you can read 3.100, this event indicate that the machine is ready to work and have acquire the machine data setting
Press the **RESET / MODE** button for 3 second to go out from the hot calibrating.

5.1 MACHINE DATA SETTING (FOR MANUFACTURER)

The machine data setting allow to fit the termoregulator at your specify application.

Press simultaneously **DOWN** and **RESET/MODE** buttons for 6 seconds (the display show **0.0.0.0.**).

- 0.0.0.0. **INITIAL MACHINE DATA CONDITION.**
- Press **RESET/MODE** button .
- 1.XXX **RAMP VALUE** (the display show the value, in grade/10 ms, of increase temperature when a pre-heating or welding command is done): the value can be set pushing the **UP** and **DOWN** button.
For increase the time to reach the preheating or welding temperature , and so increase the resistance endurance, decrease this parameter.
- Press **RESET/MODE** button .
- 2.XXX **KV GAIN**(the display show the value of linear closed loop gain): the value can be set pushing the **UP** and **DOWN** button.
For increase the speed rate of closed loop gain and so make the system speedest increase this parameter.
N.B. = An excessive KV increase can carry the system at unstable condition;in this condition the current supply are unstable and the temperature too.
- Press **RESET/MODE** button .
- 3.XXX **KINT GAIN** (the display show the integrative loop gain value): the value can be set pushing the **UP** and **DOWN** button.
In order to increase the stability of system increase this parameter.
An excessive KINT increase can carry the temperature to overflow when a preheating command is give (this parameter is not active for welding temperature / command).
- Press **RESET/MODE** button .
- 4.XXX **INTEGRATING INTERVENTION TRESHOLD KINT** (the display show the treshold value).
Should not be altered (Default value = 30).
- Press **RESET/MODE** button .
- 5.XXX **SELECTION DISPLAY °C / °F** (the display show the selected value 00C / 00F): the value can be set pushing the **UP** and **DOWN** button.
- Press **RESET/MODE** button .
- 6.XXX **POWER FREQUENCY SELECTION 50 / 60 Hz** (the display show the selected value 050 / 060): the value can be set pushing the **UP** and **DOWN** button..
- Press **RESET/MODE** button .
- 7.XXX **MAXIMUM WELDING TIME** (the display show the maximum welding time in seconds): the value can be set pushing the **UP** and **DOWN** button.
This time set the maximum welding time ,in the case that the machine time of welding is upper than this parameter, the termoregulator goes in allarm status and display F085.
For application that use the welding time forewer this parameter must be set 000; in this case the parameter 3 is activated (KINT GAIN).
- Press **RESET/MODE** button .

- **8.XXX PARTIAL SHORT CIRCUIT FACTOR**(the display show a multiplier factor of standard snap current): the value can be set pushing the **UP** and **DOWN** button.
This parameter set a threshold snap current, caused by a partial short circuit, over this parameter the thermoregulator goes in allarm and display F097.
- Press **RESET/MODE** button .
- **9.XXX D TEMPERATURE SET** (the display show a correction parameter value of welding temperature): the value can be set pushing the **UP** and **DOWN** button.
This parameter allow to correct the misstake from he welding temperature set and the working welding temperature (display by the display).
NB : From the H model of the card this parameter is automatic and so is present but not changeble by user .
- Press **RESET/MODE** button .
- **A.XXX NOMINAL CURRENT** (the display show the nominal current value 030 / 060): the value can be set pushing the **UP** and **DOWN** button.
This parameter is determinating by the hardware of thermoregulator that you buy.
NB : From the H model of the card this parameter is automatic and so is present but not changeble by user .
- Press **RESET/MODE** button .
- **B.XXX LOOP FASE NUMBER** (the display show the value 001/ 002 that correspond at fase number that the thermoregulator use for temperature control): the value can be set pushing the **UP** and **DOWN** button.
This parameter allow to control the rate of thermoregulator working : 001=50 Hz , 002=100 Hz .
We suggest to set this parameter : 002.
NB : From the H model of the card this parameter is automatic and so is present but not changeble by user .
- Press **RESET/MODE** button .
- **C.XXX COLD COMPENSATION PARAMETERS** (the display show the value 000/ 001): the value can be set pushing the **UP** and **DOWN** button.
This parameter allow to set the cold compensation parameter , 001= preheating on / 000 = preheating off; for more information about this parameter see par.5.6
- Press **RESET/MODE** button for 3 seconds to go out .

5.2 CALIBRATION RULES

The thermoregulator calibration rules is very easy the internal microprocessor guide you in this operation .
For make the putting into service and calibrating, please, follow the following instruction.

- 1- Verify that the trasformer dimensioning and protection dimensioning are correct and made as illustrated in par.4.
- 2 - Verify that the power circuit is disconnected .
- 3 - Verify that the preheating and welding command are disconnected .
- 4 - Set the dip switch **SW+** e **SW-** as write in dip switch table (See App.B)
- 5 - Insert power control circuit (CN2) 230 V AC. (the pannel display F033)
- 6 - Verify and set the machine data setting as the application require (see App. D)
- 7 - Set dip switch **SW1** as the preceding putting into service (see App.D). (in the case of first putting into service go to the following step).
- 8 - Insert the power circuit (CN1).
- 9 - Make cold balance (the cold balace is make to fit the termoregulator at the resistance) .

Turning the **BALANCING** trimmer , the both led **GREEN** and **RED** must be light simultaneously.
(clockwise rotation lights the **GREEN** led up, counter-clockwise rotation lights the **RED** led up).

The leds update is make one time for seconds, and so when you make the balancing make a rotation and wait for a moment for the update.

10 - Make the HOT CALIBRATION(the hot calibration need for the **CALIBRATING TEMPERATURE** system acquire. You must set a current (**CALIBRATING CURRENT**) that generate on the resistance 100°C / 212°F of temperature.

- Press the **RESET/MODE** and **UP** button for 6 seconds (the display show **1.1.1.1.**)
- **0.XXX CALIBRATING CURRENT** (the display show the current value in Ampere , this value must be the necessary current to bring the resistance at 100°C / 212 °F. (100°C is the **CALIBRATING TEMPERATURE**) : the current can be set pushing the **UP** and **DOWN** button.
 - Press **RESET/MODE** button .
 - **1.XXX V-I CALIBRATING** (the display show a reference value that must be included from 0.8 to 1.2) : wait for one minute when you are in this state to permit at the value to became stable; this parameters can be set modify the dip switch **SW1** impostation (See App. C) ; repeat all the operation from step 9 when you modify the dip switch **SW1** (**Rimember : wait until the welding handle is cold**).
 - Press **RESET/MODE** button .
 - **2.XXX I READ DI TARATURA** (the display show a internal parameter value , the best value is under 4.00): to modify this parameter can be set turning the **I READ** trimmer put on the power module (for the model with **I READ** dip switch see appendice C) .
NB : From the H model of the card there is dip switch **I READ** see appendice C to set it.
 - Press **RESET/MODE** button .
 - **3.A.A.A. AUTOCALIBRATING TEMPERATURE**(the display flashing show 3.A.A.A.) : during this fase the termoregulator automaticaly acquire all the machine condition : for the first 60 second the termoregulator turn off the current to permit at the welding handle to became cold , the following 60 second the termoregulator acquire the necessary data.
When termoregulator have finisched the calibration the termoregulator regulate the current to have 100°C / 212°F and the display show the temperature value .
 - Press **RESET/MODE** button .
 - **4.XXX PEAK CURRENT** (the display show the peak current value in ampere).
 - Press the **RESET/MODE** button to go out from the hot calibrating.

5.3 SETTING THE PRE-HEATING AND WELDING TEMPERATURE

- **SETTING THE PRE-HEATING TEMPERATURE** - Keep simultaneously the **RESET / MODE** e **T / I** button for 3 seconds .
The led **PREHEATING** on the panel will start to blink, while the display will show the present pre-heating temperature, which means that a new temperature can be entered. Set the desired value using the **UP** and **DOWN** buttons . (**UP** = temperature increase , **DOWN** = temperature decrease).
After 3 seconds of inactivity, the card reverts automatically to the phase in which the real temperature is displayed and new pre-heating value is stored.
- **SETTING THE WELDING TEMPERATURE** - Press the **RESET / MODE** button, ensuring that the **PRE-HEATING** led on the panel is still blinking.
The **WELDING** led will then starts blinking on the panel, and the display will show the welding temperature, indicating that a new temperature value can be entered. Set the desired value using the **UP** and **DOWN** button (**UP** = temperature increase , **DOWN** = temperature decrease).
After 3 seconds of inactivity, the card reverts automatically to the phase in which the real temperature is displayed and new pre-heating value is stored.

5.4 TEMPERATURE / CURRENT DISPLAY

By the pressing of **T / I** button we can display the resistance current or temperature of the resistance.

5.5 COLD COMPENSATION STRUCTURE OPTION (set from the machine parameter C.XXX)

0XXX INITIAL WELDING TEMPERATURE - Press the **RESET / MODE**, ensuring that the **WELDING** led is still blinking on the panel ; the display will show the **INITIAL WELDING TEMPERATURE**.
The value can be set by pushing the **UP** and **DOWN** button
After 3 seconds of inactivity, the card reverts automatically to the phase in which the real temperature is displayed and new initial pre-heating value is stored.
This temperature need to speedly arrive at the steady condition temperature the welding handle and the welding ambient when the machine is cold.

_XXX INITIAL STRUCTUR TEMPERATURE - Press **RESET / MODE** button, the display will show the **INITIAL STRUCTUR TEMPERATURE**.

The value can be set by pushing the **UP** and **DOWN** button.
After 3 seconds of inactivity, the card reverts automatically to the phase in which the real temperature is displayed and new pre-heating time value is stored.

5.6 LOADING THE MACHINE STANDARD DATA (DO NOT USE)

This procedure is used either during the testing phase of the equipment or, only by qualified personnel, in case the machine parameters are unduly altered.

1 - Turn off equipment.

2 - Press the **DOWN** and **RESET** button simultaneously . Turn on the equipment without releasing the two buttons (4 squares will be displayed).

3 - The equipment has loaded the **DEFAULT MACHINE DATA** and can be optimize.

The loading procedure of the machine data reset the termoregulators to a state that might not be the same as that of your machine. After this procedure must be verify the machine data with the table in App.D (PUTTING INTO SERVICE CARD).Otherwise dangerous situation will ensue during the operation of the sistem.

NB : from the H model the loading machine data setting change so :

For the 30 A card the point 2 is : 2 - Press the **DOWN** and **RESET** button simultaneously . Turn on the equipment without releasing the two buttons (4 squares will be displayed).

For the 60 A card the point 2 is : 2 - Press the **UP** and **RESET** button simultaneously . Turn on the equipment without releasing the two buttons (4 squares will be displayed).

6**WARNING AND ALLARM LIST (CAUSE - REMEDY)**

Display	CAUSE	REMEDY
F033	No power supply	Connect power supply.
F078	Allarm termoregulator not calibrating	You dont have made the autocalibrating. Set the machine data , make the cold balancing and hot calibrating (autocalibrating is in this fase).
F081	Check-sum alarm (Hardware problem)	Contact manufacturer or press RESET / MODE .
F082	Phase displacement alarm from power supply (CN2) and power control supply (CN2)	Modify electric installation (see Cap 3.4 wiring diagram)
F083	Resistance reference inverted alarm (CN3/6 - CN3/7)	Invert resistance reference cable.
F084	Secondary power trasformer tension too high alarm	Verify trasformer dimensioning (Cap 4.1) Verify dip switch SW+ SW- set-up.
F085	Alarm : welding time superior to set machine data : 7.XXX	Load new maximum time and verify the time managing electronic.
F086	Alarm: network deccreas under variation of 10 %.	Verify the supply tension and press RESET / MODE button .
F087	Alarm: network deccreas under variation of 10 % when a pre-heating or welding is given.	Verify the supply tension and press RESET / MODE button.
F089	Alarm : welding resistance defect with parallel connection resistance.	Substitute resistance and /or welding wire.
F090	Short circuit alarm between resistance or resistance and earth.	Verify into machine if there is a short circuit
F091	I ² T Alarm	Verify that there is not anomal absorbtion
F092	Alarm : power component defect	Hardware problem, contact manufacturer
F093	Alarm : welding resistance defect with serial connection resistance	Substitute resistance and /or welding wire.
F094	Alarm : refence resistance cable defect (CN3/6 - CN3/7)	Verify connection CN3/6 - 7 with resistance
F095	Alarm : no network synchronism	Hardware problem, contact manufacturer
F096	Alarm : V-I error Calibrating	Verify dip switch SW1 set-up Verify BALANCING trimmer position
F097	Alarm : partial short circuit between resistance or resistance and earth.	Verify resistance and handle welding

THERMOSALD-EDIZIONE '99/05**NOTE - For resetting alarms press RESET / MODE button.**

7 DATA FOR ORDER

MODEL	DESCRIPTION	CODE
10030 SCR uP	Impulse termoregulator 100V 30A	3ESD0044X
10060 SCR uP	Impulse termoregulator 100V 60A	3ESD0045X
PANEL	Digital panel for data setting	3ESD0039X
CABLE	Connection cable panel - termoregulator (mt.5)	3ESD0035X
OPTION		
/L	LOW VOLTAGE version for short resistance (20V MAX)	
/N	PLC command (pre-heating, welding) NPN type	
/S	RS232 serial interface (available from 01/09/97)	
ACCESSORIES		
	Amperemeter 30 / 60 A (direct insertio)	
	Amperometric power trasformer : ratio 60 / 1	
	Amperemeter 30 / 60 A (to use with T.A. end scale 1 A)	
	Power trasformer 1000 VA 0 / 230 / 400 / SCH / GND = 0 / 10 / 24 / 48	
	Power trasformer 1400 VA 0 / 230 / 400 / SCH / GND = 0 / 30 / 40 / 50 / 60 / 70	
	Resistance and welding wires of any type : in meters, coppered, silvered and teflonated.	

ORDER EXAMPLE

For order N.1 Impulse termoregulator 100V 30A, LOW VOLTAGE version for short resistance and PLC commands type PNP you must order :

N.1	10030 SCR uP Impulse termoregulator 100V 30A LOW VOLTAGE version for short resistance PLC commands type PNP	3ESD0044E /L /N
N.1	PANEL Digital panel for data settings	3ESD0039X
N.1	CABLE Connection cable	3ESD0035X

8 DIMENSIONS

SIDE VIEW

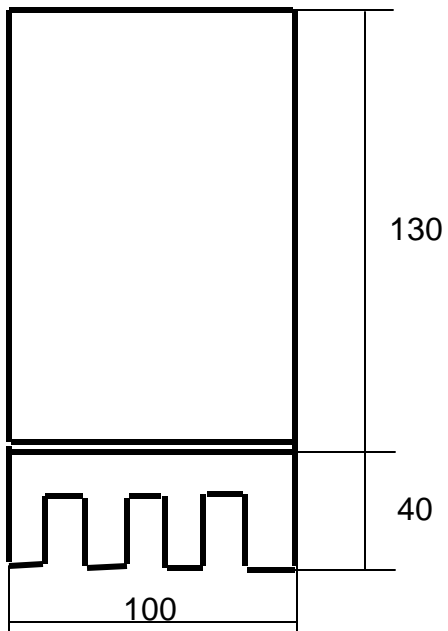

FRONT VIEW

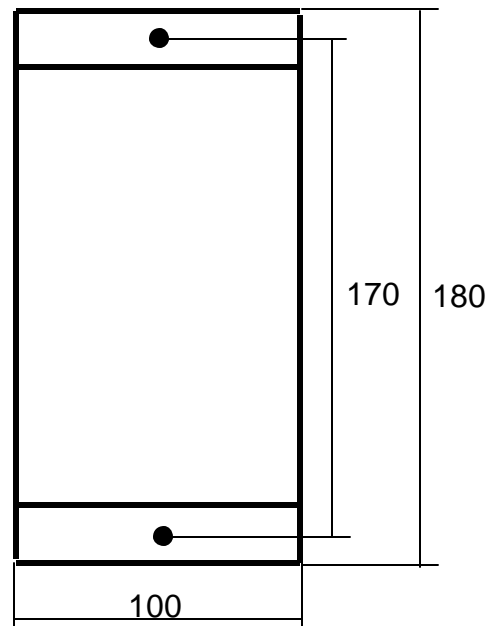

PANEL EXTERNAL DIMENSION

BREAKING UP PANEL

Appendix A

WELDING CYCLE

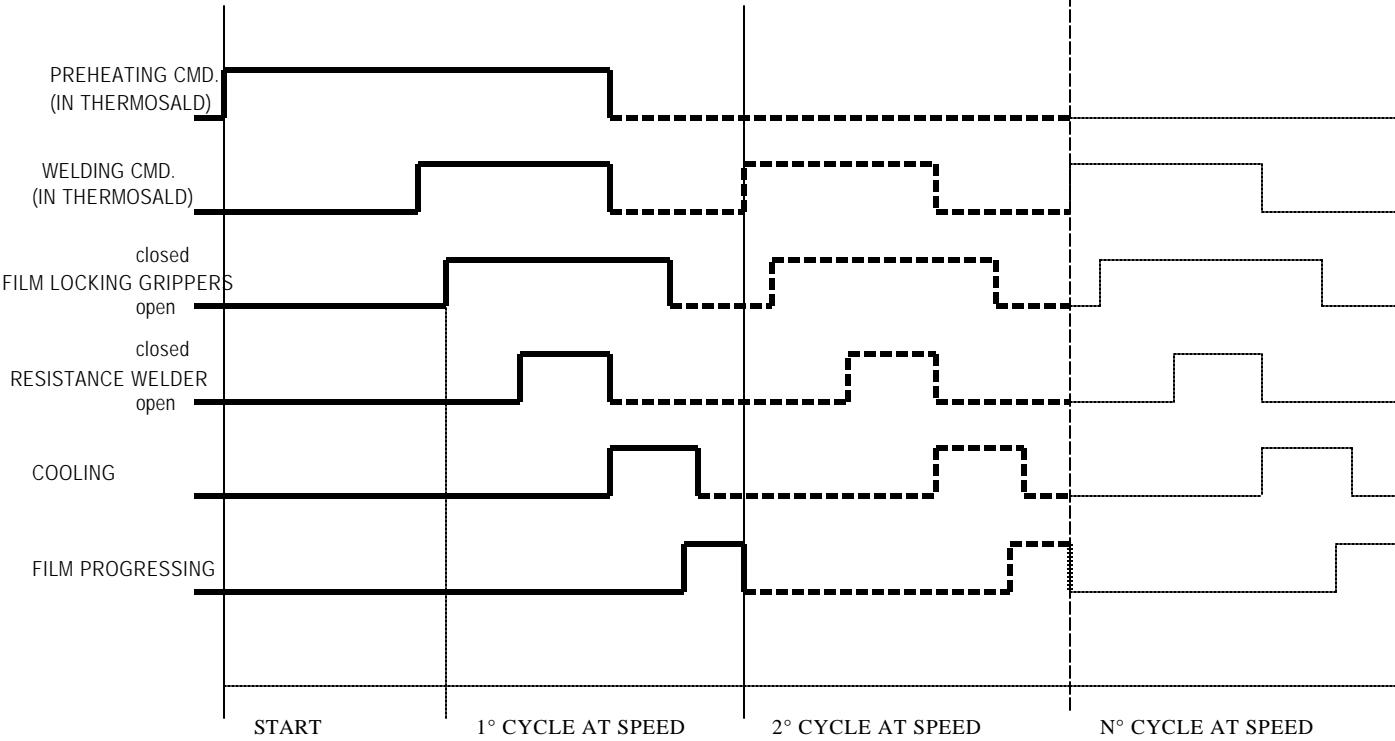

APPENDIX B - DIP SWITCH SW+ AND SW- TABLE

Dip 1	Dip 2	Dip3	Dip4	TRASFORMER TENSION VALUE	
ON	ON	ON	ON	5 - 7	(GREEN LED)
OFF	ON	ON	ON	8 - 15	
ON	OFF	ON	ON	16 - 25	
OFF	OFF	ON	ON	26 - 35	
ON	ON	OFF	ON	35 - 42	
OFF	ON	OFF	ON	43 - 50	
ON	OFF	OFF	ON	51 - 57	
OFF	OFF	OFF	ON	58 - 65	
ON	ON	ON	OFF	66 - 75	
OFF	ON	ON	OFF	76 - 82	
ON	OFF	ON	OFF	83 - 92	
OFF	OFF	ON	OFF	92 - 97	
ON	ON	OFF	OFF	98 - 100	
OFF	ON	OFF	OFF	-	
ON	OFF	OFF	OFF	-	
OFF	OFF	OFF	OFF	-	(RED LED)

NOTE - This table is used to fit the secondary trasformer tension (see **TRASFORMER DIMENSIONING** Cap 4.1) to termoregulator.
Set the dip switch in base of secondary trasformer tension.

NOTE - If you do not obtain the **GREEN - RED** balancing follow this instruction :

- If the **RED** led is light and the **GREEN** is off : utilize the upper dip-swicth set-up suggested.
- If the **GREEN** led is light and the **RED** is off : utilize the upper dip-swicth set-up suggested.

NOTE - the **NOMINAL TANSFORMATOR VALUE** is the parameter that you always must apply in the dip switch **SW+** and **SW-** setting, even if the real tension apply are different. (Es: Resistance : 1 Ω Card : 30 A - **NOMINAL TANSFORMATOR VALUE = 30 V** - Tension Apply = **40 V** - **DIP SWITCH SW+ and SW- = OFF OFF ON ON for tension between 26V and 35V**

APPENDIX C - DIP SWITCH SW1 AND IREAD TABLE

SW1 DIP SWITCH TABLE

NOTE

The dip switch SW1 can modify the **V-I BALANCING** (See cap. 5.2 / 10 / 1.XXX)

The corret position of dip switch SW1 is found during the first put into service, you must do the **HOT CALIBRATING**.

The **V-I BALANCING** should be between 0.8 and 1.6 :

- for increase this value increase gain (see the following table);

- for decrease this value decrease gain (see the following table).

Dip 1	Dip 2	Dip3	Dip4	Gain	
ON	ON	ON	ON	5	(DECREASE V - I VALUE)
OFF	ON	ON	ON	10	
ON	OFF	ON	ON	15	
OFF	OFF	ON	ON	20	
ON	ON	OFF	ON	25	
OFF	ON	OFF	ON	30	
ON	OFF	OFF	ON	35	
OFF	OFF	OFF	ON	40	
ON	ON	ON	OFF	45	
OFF	ON	ON	OFF	50	
ON	OFF	ON	OFF	55	
OFF	OFF	ON	OFF	60	
ON	ON	OFF	OFF	65	
OFF	ON	OFF	OFF	70	
ON	OFF	OFF	OFF	75	
OFF	OFF	OFF	OFF	80	(INCREASE V - I VALUE)

IREAD DIP SWITCH TABLE

NOTE

The dip switch SW-IREAD can modify the **IREAD** (See cap. 5.2 / 10 / 1.XXX)

The corret position of dip switch SW1 is found during the first put into service, you must do the **HOT CALIBRATING**.

The **IREAD** value must be near 4.00 :

- for increase this value increase gain (see the following table);

- for decrease this value decrease gain (see the following table).

Dip 1	Dip 2	Dip3	Dip4	Gain	
ON	ON	ON	ON	5	(DECREASE IREAD VALUE)
OFF	ON	ON	ON	10	
ON	OFF	ON	ON	15	
OFF	OFF	ON	ON	20	
ON	ON	OFF	ON	25	
OFF	ON	OFF	ON	30	
ON	OFF	OFF	ON	35	
OFF	OFF	OFF	ON	40	
ON	ON	ON	OFF	45	
OFF	ON	ON	OFF	50	
ON	OFF	ON	OFF	55	
OFF	OFF	ON	OFF	60	
ON	ON	OFF	OFF	65	
OFF	ON	OFF	OFF	70	
ON	OFF	OFF	OFF	75	
OFF	OFF	OFF	OFF	80	(INCREASE IREAD VALUE)

NOTES

Welding resistance value = _____ Ω
Power secondary transformation value = _____ V
Pre-heating temperature = _____ $^{\circ}$
Welding temperature = _____ $^{\circ}$
Cold initial welding temperature = _____ $^{\circ}$
Structure temperature = _____ $^{\circ}$